

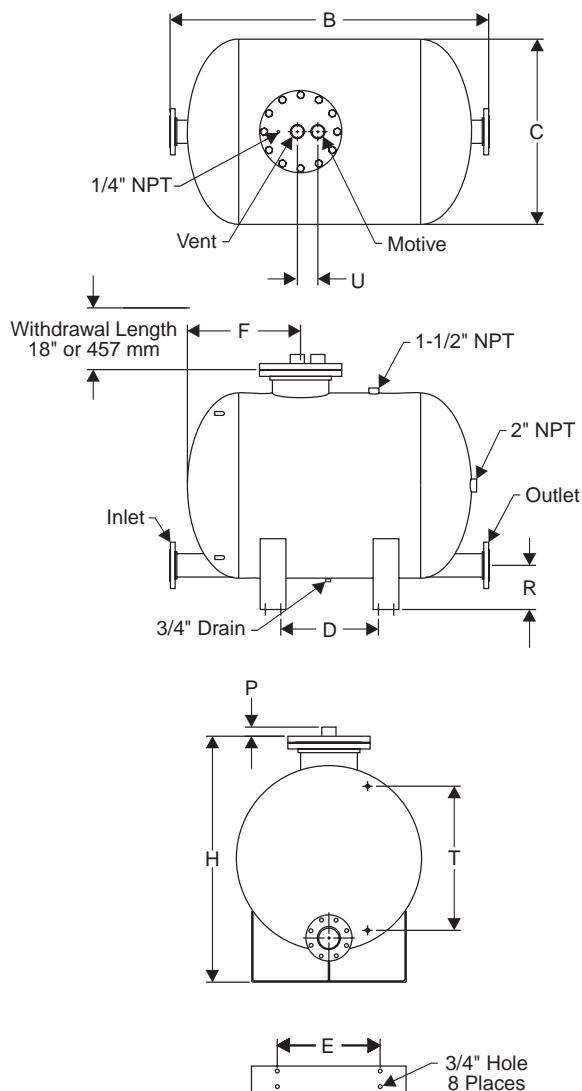

Armstrong® PT-516 High Capacity Pump Trap



Condensate Recovery Equipment



Effective recovery and return of hot condensate are essential to overall plant efficiency while conserving energy. Large amounts of condensate provide the best opportunities to save energy.

The Armstrong PT-516 High Capacity Pump Trap is the low maintenance, non-electric solution to moving large amounts of condensate and other liquids from low points, low pressures or vacuum spaces to an area of higher elevation or pressure. Condensate can be returned at temperatures well above the 200°F (93°C) limit of conventional electric pumps without the headaches of leaking seals or cavitation.

Features

- Non-electric—Uses inexpensive steam, air or gas to operate the pump trap
- No leaking seals/packings, impeller wear, electrical or motor problems—Reduces maintenance and downtime
- Single trade installation or repair reduces installation and maintenance costs
- Direct spring/float actuated mechanism—No maintenance intensive diaphragm operated valve mechanism
- Compression spring design—Reduces downtime, ensures performance and reliability
- Rugged stainless steel internals—Durable and corrosion resistant for enhanced service life
- Closed loop—No motive steam or flash steam loss, therefore capturing and returning all valuable Btu back to the system (see General Applications on page CRE-33)
- Safety—Pump can be placed in flooded pits without fear of electrocution or circuit breaker defaults
- Standard unit intrinsically safe

For a fully detailed certified drawing, refer to CDF #1017.

PT-516 High Capacity Pump Trap Physical Data

	in	mm
Inlet Connection	4 150# ANSI Flg.	100 150# ANSI Flg.
Outlet Connection	4 150# ANSI Flg.	100 150# ANSI Flg.
Motive Connection	2 NPT	50 NPT
Vent Connection	2 NPT	50 NPT
Gauge Glass Conn.	1/2 NPT	15 NPT
"B"	62	1,574
"C"	36	914
"D"	19-1/16	484
"E"	20	508
"F"	22	559
"H"	48	1,219
"P"	1-3/4	44
"R"	8-3/4	222
"T"	28	711
"U"	4	100
Weight	807	366
Number of Bolts	12	12

Maximum Operating Pressure on standard unit: 150 psig (10 bar).
 For higher pressure, consult factory.
 Maximum Allowable Pressure (standard vessel design): 150 psig @ 500°F (10 bar @ 277°C).
 300 psi (21 bar) vessel available upon request.

PT-516 Capacity Conversion Factors for Other Fill Heads

Fill Head	in	mm	in	mm	in	mm	in	mm	in	mm	in	mm
	0	0	6	152	12	305	16	406	24	610	36	914
PT-516	0.7		0.75		0.8		0.85		1.0		1.08	

Discharge per cycle is typically 130 gallons.

All dimensions and weights are approximate. Use certified print for exact dimensions. Design and materials are subject to change without notice.



PT-516 High Capacity Pump Trap

Typical Applications

- Low pressure heating systems
- Process heat exchanger or coils with modulating steam control
- Remote installations (tracing, tank farms or remote coils)
- Systems under vacuum
- Hazardous (explosion proof) areas
- Caustic environments
- Sumps or submersed areas

PT-516 High-Capacity Pump Trap Materials	
Name of Part	Description
Cap, Body, Bolting	Fabricated steel 150 psi ASME Sec. VIII design "U" stamp coded
Cap Gasket	Compressed non-asbestos
Inlet Valve Assembly	Stainless steel
Vent Valve Assembly	Stainless steel
Mechanism Assembly: Frame, Float and Spring	Stainless steel

NOTES: 300 psi ASME vessel available upon request. PT-516 available in all stainless steel. Consult factory.

Armstrong PT-516 Pump Trap Sizing and Selection

PT-516 Pump Trap Capacities									
Motive Pressure		Total Lift or Back Pressure		4" x 4" Connections 24" Fill Head					
				Steam Motive		Air Motive			
psig	bar	psig	bar	lb/hr	kg/hr	lb/hr	kg/hr		
15	1.0	5	0.34	28,962	13,137	57,619	26,136		
25	1.7			37,162	16,857	61,911	28,083		
35	2.5			42,563	19,307	64,738	29,365		
50	3.5			48,288	21,903	67,735	30,725		
60	4			51,214	23,231	69,267	31,420		
70	4.5			53,688	24,138	70,562	32,007		
75	5			54,796	24,855	71,142	32,270		
100	7			59,414	26,950	73,559	33,366		
125	8.5			62,995	28,575	*	*		
150	10.34			65,922	29,902	*	*		
25	1.7	15	1	36,720	16,656	50,783	23,035		
35	2.5			40,611	18,421	54,293	24,627		
50	3.5			45,196	20,501	58,013	26,315		
60	4			47,740	21,655	59,915	27,177		
70	4.5			50,005	22,682	61,523	27,907		
75	5			51,054	23,159	62,243	28,233		
100	7			55,675	25,254	65,243	29,594		
125	8.5			59,552	27,013	*	*		
150	10.34			62,923	28,542	*	*		
35	2.5			25	1.7	29,212	13,251	46,238	20,973
50	3.5	33,413	15,156			50,962	23,116		
60	4	35,672	16,181			53,376	24,211		
70	4.5	37,646	17,076			55,418	25,138		
75	5	38,548	17,485			56,313	25,544		
100	7	42,454	19,257			60,141	27,280		
125	8.5	45,649	20,706			*	*		
150	10.34	*	*			*	*		
50	3.5	40	3			26,210	11,889	41,244	18,708
60	4					27,353	12,407	44,028	19,971
70	4.5			28,319	12,846	46,382	21,039		
75	5			28,752	13,042	47,435	21,517		
100	7			30,555	13,860	51,828	24,022		
125	8.5			31,954	14,494	*	*		
150	10.34			33,097	15,013	*	*		
70	4.5			60	4	25,973	11,781	32,026	14,527
75	5					26,373	11,963	33,514	15,202
100	7					28,042	12,720	40,951	18,575
125	8.5	29,336	13,307			*	*		
150	10.34	30,394	13,787			*	*		
100	7	80	5.5			23,892	10,837	34,893	15,827
125	8.5					24,231	10,991	*	*
150	10.34					24,570	11,145	*	*

NOTES: Published capacities above are based on actual steam testing using a minimum 200°F condensate. Published capacities are based on the use of external check valves supplied by Armstrong.
*Consult factory.

Options

- External check valves required for use of pumping trap.
- Inlet/Outlet Check Valve
CS/SS Wafer Style or All Stainless Steel Wafer Style
 - Bronze 6.6 Assembly
 - Removable Insulation Jacket
 - Digital Cycle Counter

All dimensions and weights are approximate. Use certified print for exact dimensions. Design and materials are subject to change without notice.



Reservoir and Vented Receiver Sizing— PT-516 Series High Capacity

Either a closed reservoir pipe or a vented receiver is required for proper condensate storage during the pump-down cycle of the pumping trap. Refer to the tables for sizing.

For Closed Reservoir Piping

- Determine condensate load.
Example 30,000 lb/hr:
 - Reference the Inlet Reservoir Pipe table top right. Find the 30,000 lb/hr condensate load in column one. Move across the columns to find the proper pipe sizing.

For Vented Receiver Sizing

- Determine the pressure from where the condensate is being discharged.
- Determine condensate load.
 - Reference the chart below to find the pressure that corresponds with the discharge condensate pressure. For this example, use 15 psig.
 - Follow 15 psig to where it intersects the "0" psig curve. Move to the left from intersecting lines for the percentage of flash that will be created. For this example, it will be 3%.
 - Multiply the 3% by the condensate load. For this example, it is 30,000 lb/hr. Thus, $30,000 \times .03 = 900$ lb/hr of flash steam.

Using the Vented Receiver table bottom right, find the amount of flash steam in column one. Follow the table across to determine the sizing of the vented receiver.

Percentage of Flash Steam Formed
When Discharging Condensate to Reduce Pressure

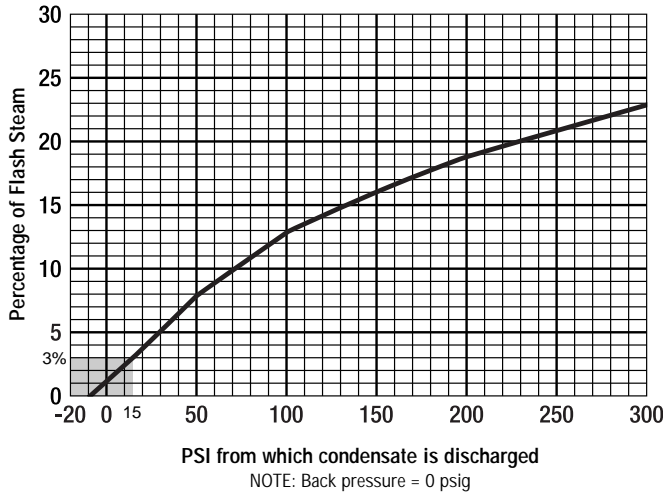

PT-516 Inlet Reservoir Pipe Sizing for Closed Systems						
Condensate Load lb/hr	Reservoir Pipe Diameter (in)					
	8	10	12	16	20	24
up to	Length of Pipe (feet)					
10,000	6-1/2	6	5	3	2	
20,000	12	11-1/2	10	7	4	
30,000		12	10-1/2	9	6	4
40,000		17	14	12	8	6
50,000			16	13	9	6
60,000				15	11	8
70,000					15	10

NOTE: When BP/MP is less than 50%, the reservoir diameters above can be reduced by 1/2" (15 mm). When draining condensate from a single piece of equipment in a closed system, to achieve maximum energy efficiency (see Closed System figure on page CRE-33) a reservoir should be installed horizontally above and ahead of the pump trap. Sufficient reservoir volume is required above the filling head level to hold condensate during the pump trap discharge cycle. The table above shows the minimum reservoir sizing, based on the condensate load, to prevent equipment flooding during the pump trap discharge cycle.

PT-516 Vented Receiver for an Open System			
Flash Steam lb/hr	Receiver Diameter (in)	Receiver Length (in)	Vent Line Diameter (in)
up to			
1,000	16	60	6
2,000	20	60	8
3,000	24	60	8
4,000	26	60	10
5,000	28	60	10
6,000	30	72	12
7,000	32	72	12
8,000	36	72	14

NOTE: When draining from single or multiple pieces of equipment in an open system, a vented receiver should be installed horizontally above and ahead of the pump trap (see Open System figure on page CRE-33). In addition to sufficient holding volume of the condensate above the fill head of the pump trap to hold the condensate during the pump trap cycle, the receiver must also be sized to allow enough area for flash steam and condensate separation. An overflow could also be added when required. The minimum recommended water seal is 12" (305 mm). The table above shows proper receiver tank sizing based on flash steam present. See chart left to calculate the percentage (%) of flash steam at a given pressure drop.

All dimensions and weights are approximate. Use certified print for exact dimensions. Design and materials are subject to change without notice.